

Manufacturers of
Garden Wall Systems
Barrier Wall Systems

General Overview Only

Wall Type: Contemporary, Traditional & Estate
Wall Heights: 900mm – 3000mm

This information is suitable for use in wind regions A, B & C of AS 1170.2-2002 SAA Loading Code. If you have any doubt about the wind region your wall will be in, get advice from your local building consent authority. It is the responsibility of the installer/owner to determine the wind region, terrain category and soil conditions. This publication is a guide only to help ascertain these factors.

Wall types covered in this guide are:

- **Contemporary:** available heights from 900mm – 2100mm

Contemporary walls have an overall panel thickness of 40mm and a 90mm top wall capping. Posts measure 150 (face) x 100 mm. Each standard panel has an effective coverage of 2.5 or 2.8 meters, post centre to post centre. The contemporary wall is the most cost effective of the 3 styles and most commonly used in domestic boundary/screening wall applications. This style of wall will also supply great sound reduction qualities.

Wall Panel 40mm thickness - Density of composite panel materials: 14.65kg m²

Post - 150 (width) x 100 (depth) x 0.95 mm BMT G550 (Table 1)
Post spacing's – 2500mm & 2800mm

- **Traditional:** available heights from 900mm – 3000mm

Traditional walls have an overall panel thickness of 75mm and a 120mm top wall capping. Posts measure 250mm (face) x 150 mm (depth) and designed around a rendered brick in width. Each standard panel has an effective coverage of 2.6, 2.9 or 3.2 meters, post centre to post centre. The Traditional wall is most commonly used where a true rendered masonry wall look is desired or in a commercial security/sound wall application. The wall has superb sound reduction qualities (National Acoustic Laboratory tested).

Wall Panel 75mm thickness - Density of composite panel materials: 15.0kg m²

Post - 250 (width) x 150 (depth) x 0.95 mm BMT G550 (Table 2)
Post spacing's – 2600mm, 2900mm & 3200mm

- **Estate:** available heights from 900mm – 3000mm

Estate walls have an overall panel thickness of 75mm and a 120mm top wall capping. Posts measure 350 (face) x 235 mm. Each standard panel has an effective coverage of 2.7, 3.0 or 3.3 meters, post centre to post centre. The Estate wall is most commonly used where a true 'Grand' rendered masonry wall look is desired. The post face is equivalent to a brick & a half in width. The wall has superb sound reduction qualities (National Acoustic Laboratory tested)

Wall Panel - 75mm thickness - Density of composite panel materials: 15.0kg m²

Post - 350 (width) x 235 (depth) x 0.95 mm BMT G550 (Table 3)
Post spacing's – 2700mm, 3000mm & 3300mm

Wind Regions

Wind Class [Regions A & B (non cyclonic), Region C (cyclonic)]

Wind region A - with ultimate limit state design gust wind speeds up to

50 meters/second or 180kph.

Wind region B - up to 50 meters/second or 180 kph

Wind region C - up to 60 meters/second or 216 kph

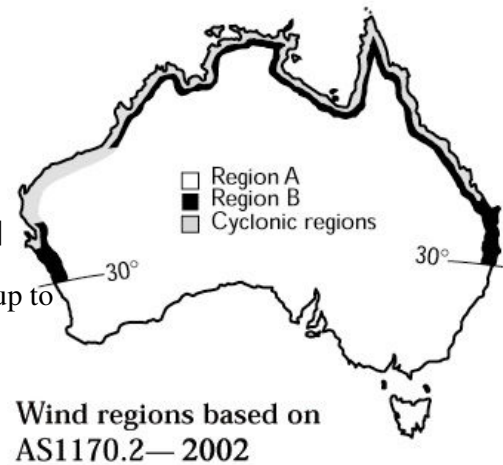

Topographic Class - T1, T2, T3, T4, T5

The Topographic class determines the effect of wind on a house because of its location on a hill, ridge, or escarpment and the height and average slope of the hill, ridge or escarpment.

Please consult MWS for help in determining your topographic class.

Shielding Class – FS (full shielding), PS (partial shielding), NS (no shielding)

FULL SHIELDING (FS) - Typical suburban developments greater or equal to 10 houses or similar size obstructions per hectare.

PARTIAL SHIELDING (PS) - This applies to intermediate situations where there are at least 2.5 houses, trees, sheds or similar size obstructions per hectare. Wind regions C & D, heavily wooded areas will be classed as having partial shielding.

NO SHIELDING (NS) - This applies when there are no permanent obstructions or where there are less than 2.5 obstructions per hectare. An example of this could be the first 2 rows of housing abutting open parklands, airfields or coast line.

Determine Your Terrain Category

Terrain Categories - TC1, TC2, TC2.5, TC3

Choose the terrain category that best describes the area in which your Modular wall will be installed. If you are unsure of your terrain category or are planning on building a wall on the top of a hill or the edge of a cliff or in terrain category 1 etc, please contact us directly for specific engineering advice.

CATEGORY 1 (TC1) Exposed and open areas with very few obstructions. This is not a common terrain category and exists only in flat, plant and treeless plains of at least 10km in width

CATEGORY 2 (TC2) Open Terrain such as sea coasts, airfields, open fields and paddocks, grassland with few scattered obstructions, such as isolated trees and uncut grass, having heights from 1.5 to 10m.

CATEGORY 2.5 (TC2.5) Terrain with few isolated obstructions and trees such as agricultural land, cane fields or long grass. This is an intermediate class in between TC2 and TC3 and represents the terrain in developing outer urban areas.

CATEGORY 3 (TC3) This terrain category has numerous closely spaced obstructions such as suburban housing. (3.0 meters to 5.0 meters high)

WIND REGION INSTALLATION TABLE 1: Modular Wall System –

TABLE 1 Garden Wall System – **CONTEMPORARY**

Post section = 150 mm width x 100 mm depth

<u>Wall Height</u> <u>(millimetres)</u>	<u>Terrain Category</u>	<u>Wind Region</u> <u>A</u>	<u>Wind Region</u> <u>B</u>	<u>Wind Region</u> <u>C (2.5 post centres</u> <u>only)</u>
900 *See notes below	TC 2.0	Yes	Yes	Yes *2.5m centre
	TC 2.5	Yes	Yes	Yes *2.5m centre
	TC 3.0	Yes	Yes	Yes *2.5m centre
1200 *See notes below	TC 2.0	Yes	Yes	Yes *2.5m centre
	TC 2.5	Yes	Yes	Yes *2.5m centre
	TC 3.0	Yes	Yes	Yes *2.5m centre
1500 *See notes below	TC 2.0	Yes	Yes	Yes *2.5m centre
	TC 2.5	Yes	Yes	Yes *2.5m centre
	TC 3.0	Yes	Yes	Yes *2.5m centre
1800 *See notes below	TC 2.0	Yes	Yes	Yes *2.5m centre
	TC 2.5	Yes	Yes	Yes *2.5m centre
	TC 3.0	Yes	Yes	Yes *2.5m centre
2100 *See notes below	TC 2.0	Yes	Yes	No
	TC 2.5	Yes	Yes	No
	TC 3.0	Yes	Yes	No

* ALL CONTEMPORARY POSTS IN WIND REGION C MUST BE CORE FILLED TO A MIN. 100MM ABOVE NOMINAL GROUND LEVEL – see page 13 of the installation manual

TABLE 2 Garden Wall System – **TRADITIONAL**

Post section = 250 mm width x 150 mm depth

<u>Wall Height</u> <u>(millimetres)</u>	<u>Terrain Category</u>	<u>Wind Region</u> <u>A</u>	<u>Wind Region</u> <u>B</u>	<u>Wind</u> <u>Region C</u> <u>(2.6 post centres</u> <u>only)</u>
900	TC 2.0	Yes	Yes	Yes *2.6m centre
	TC 2.5	Yes	Yes	Yes *2.6m centre
	TC 3.0	Yes	Yes	Yes *2.6m centre
1200	TC 2.0	Yes	Yes	Yes *2.6m centre
	TC 2.5	Yes	Yes	Yes *2.6m centre
	TC 3.0	Yes	Yes	Yes *2.6m centre
1500	TC 2.0	Yes	Yes	Yes *2.6m centre
	TC 2.5	Yes	Yes	Yes *2.6m centre
	TC 3.0	Yes	Yes	Yes *2.6m centre
1800	TC 2.0	Yes	Yes	Yes *2.6m centre
	TC 2.5	Yes	Yes	Yes *2.6m centre
	TC 3.0	Yes	Yes	Yes *2.6m centre
2100	TC 2.0	Yes	Yes	Yes *2.6m centre
	TC 2.5	Yes	Yes	Yes *2.6m centre
	TC 3.0	Yes	Yes	Yes *2.6m centre
2400	TC 2.0	Yes	Yes	No
	TC 2.5	Yes	Yes	No
	TC 3.0	Yes	Yes	Yes *2.6m centre
2700	TC 2.0	Yes	Yes	No
	TC 2.5	Yes	Yes	No
	TC 3.0	Yes	Yes	No
3000 *see 3000mm specific wall installation instructions on page 13 of the installation manual	TC 2.0	No	No	No
	TC 2.5	*Yes	*Yes	No
	TC 3.0	*Yes	*Yes	No

TABLE 3 Garden Wall System – ESTATE

Post section = 350 mm width x 235 mm depth

Wall Height (millimetres)	Terrain Category	Wind Region	Wind Region	Wind Region
		A	B	C
900	TC 2.0	Yes	Yes	Yes *2.7m centre
	TC 2.5	Yes	Yes	Yes *2.7m centre
	TC 3.0	Yes	Yes	Yes *2.7m centre
1200	TC 2.0	Yes	Yes	Yes *2.7m centre
	TC 2.5	Yes	Yes	Yes *2.7m centre
	TC 3.0	Yes	Yes	Yes *2.7m centre
1500	TC 2.0	Yes	Yes	Yes *2.7m centre
	TC 2.5	Yes	Yes	Yes *2.7m centre
	TC 3.0	Yes	Yes	Yes *2.7m centre
1800	TC 2.0	Yes	Yes	Yes *2.7m centre
	TC 2.5	Yes	Yes	Yes *2.7m centre
	TC 3.0	Yes	Yes	Yes *2.7m centre
2100	TC 2.0	Yes	Yes	Yes *2.7m centre
	TC 2.5	Yes	Yes	Yes *2.7m centre
	TC 3.0	Yes	Yes	Yes *2.7m centre
2400	TC 2.0	Yes	Yes	Yes *2.7m centre
	TC 2.5	Yes	Yes	Yes *2.7m centre
	TC 3.0	Yes	Yes	Yes *2.7m centre
2700	TC 2.0	Yes	Yes	No
	TC 2.5	Yes	Yes	No
	TC 3.0	Yes	Yes	No
3000 <small>*see 3000mm specific wall installation instructions on page 13 of the installation manual</small>	TC 2.0	No	No	No
	TC 2.5	*Yes	*Yes	No
	TC 3.0	*Yes	*Yes	No

Footing Detail:

This information is suitable for wind region A, B & C - terrain categories 2, 2.5 & 3

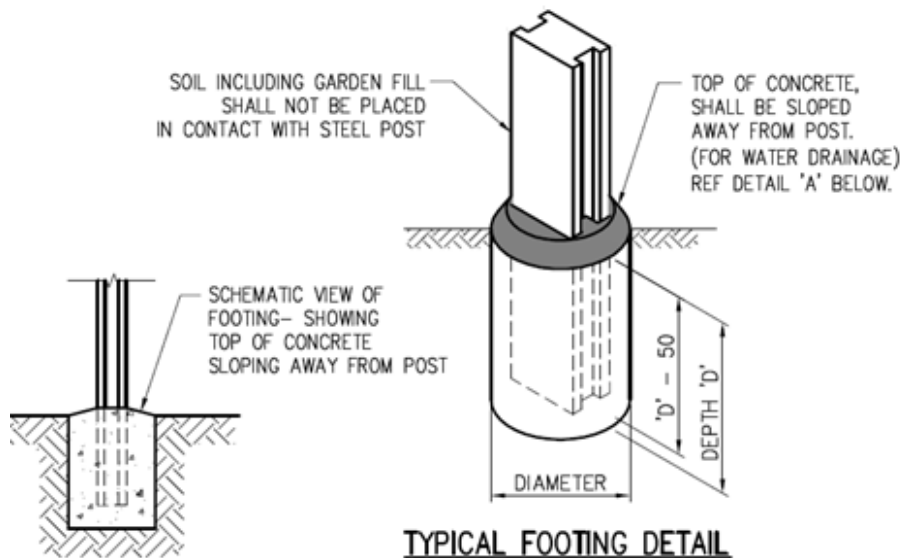

Footing Table:

If you want to build on the top of a hill, adjacent to an escarpment, on a ridge, or in terrain category 1, you may need engineering advice beyond the scope of this publication.

Wall height	Hole depth (D) into firm earth or clay (cohesive)		Hole depth (D) Into sand (cohesion less), soft clay or loose earth		Hole diameter - will vary between Contemporary, Traditional and Estate post sizes
	A & B	C	A & B	C	
900mm	450mm	650mm	550mm	800mm	Post Hole diameter should be your post width plus 100mm
1200mm	550mm	750mm	650mm	900mm	Post Hole diameter should be your post width plus 100mm
1500mm	600mm	900mm	700mm	1000mm	Post Hole diameter should be your post width plus 100mm
1800mm	650mm	1000mm	800mm	1100mm	Post Hole diameter should be your post width plus 100mm
2100mm	700mm	1100mm	900mm	1200mm	Post Hole diameter should be your post width plus 100mm
2400mm	800mm	1200mm	1000mm	1300mm	Post Hole diameter should be your post width plus 100mm
2700mm	900mm	N/A	1100mm	N/A	Post Hole diameter should be your post width plus 100mm
3000mm *see 3000mm specific wall installation specs on p 13 of the installation manual	1000mm	N/A	1200mm	N/A	Post Hole diameter should be your post width plus 100mm

Typical Cross Section

